



STAINLESS STEEL CENTRIFUGAL FANS CAI





STAINLESS STEEL CENTRIFUGAL FANS CAI

- Centrifugal duct fans to extract air and fumes with chemical agents or for salt ambients.

- Body and impeller in AISI 304 stainless steel.

- Also suitable for application on machines where a forced ventilation or air suction is required.

- Particularly suitable for applications where a high degree of hygiene (food industries) is necessary.

- Stainless steel blade statically and dynamically balanced.

- High pressures to overcome pressure losses due to duct resistance.

- Impeller housing can be installed in any different position with possibility of opposite rotation (on request, see table page 59).

The standard product is supplied with impeller housing position CCW 270.

- Fans with specialised motors are available on request i.e. Flameproof, Tropicalised.

- Maximum temperature of exhausted air 70°C.

- In accordance with the essential requirements of 89/392/CE directive concerning machines, and with European Standards EN 292 part I and II, UNI EN 294 and IEC 204-1 and 2.

- Industrial regulators available (see page 88).

For models CAI 530 and CAI 540:

- Motor with ball bearings.

- IP55 protected.

Dimensions

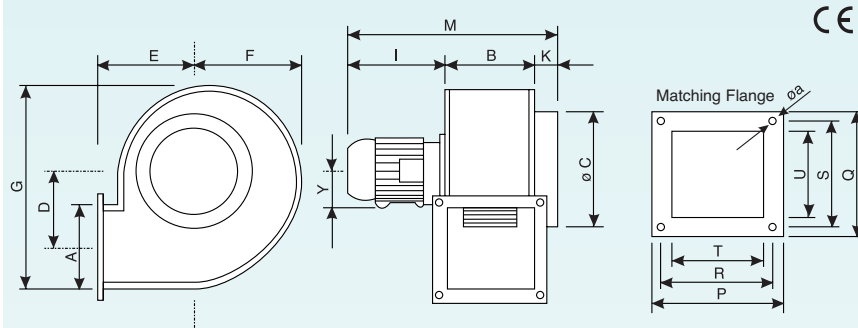

Model	A	B	øC	D	E	F	G	Y	K	I	M	P	Q	R	S	T	U	ø d	n _{fori}	Kg
CAI510 2M	60	62	68	50	86	72	145	-	-	110	172	100	100	85	85	58	58	6	4	2,5
CAI510 2T	60	62	68	50	86	72	145	-	-	110	172	100	100	85	85	58	58	6	4	2,5
CAI520 2M	71	77	90	60	104	80	171	-	-	121	198	114	110	95	90	69	63	7	4	3,5
CAI520 2T	71	77	90	60	104	80	171	-	-	121	198	114	110	95	90	69	63	7	4	3
CAI530 2M	97	98	180	92	128	124	248	63	38	191	327	135	135	114	114	88	88	8	4	8,5
CAI530 2T	97	98	180	92	128	124	248	63	38	191	327	135	135	114	114	88	88	8	4	7
CAI540 2M	112	110	200	116	145	150	300	71	40	213	363	150	150	125	125	105	105	8	4	9
CAI540 2T	112	110	200	116	145	150	300	71	40	213	363	150	150	125	125	105	105	8	4	9

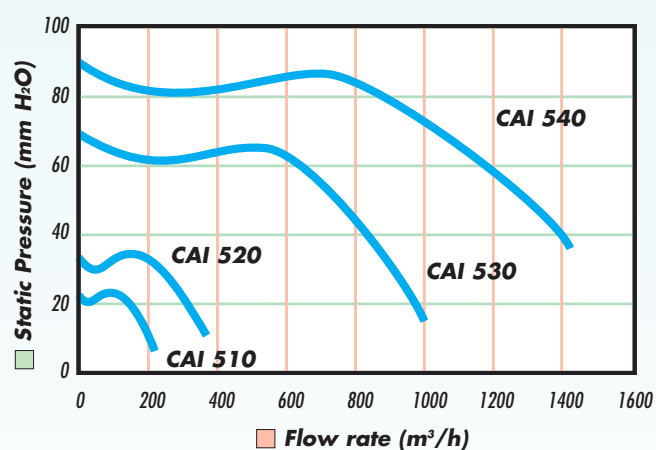

Technical Data

Model	Ref.	Motor Protection	Motor	Flow rate m ³ /h	Max.Press. mm H ₂ O	N° Poles	W	Hz	Nom.Cur. in A. at 230V/at 400V	dB (A) 2 m	RPM	
CAI 510 2M	OW 480 6	IP22	single-phase	210	22	2	67	50	0,29	-	64	2800
CAI 510 2T	OW 481 4	IP22	three-phase	210	22	2	67	50	0,26	0,15	64	2800
CAI 520 2M	OW 482 2	IP22	single-phase	350	33	2	115	50	0,49	-	68	2500
CAI 520 2T	OW 483 0	IP22	three-phase	350	33	2	110	50	0,36	0,21	68	2500
CAI 530 2M	OW 484 8	IP55	single-phase	1000	69	2	590	50	2,83	-	76	2750
CAI 530 2T	OW 485 5	IP55	three-phase	1000	69	2	400	50	1,40	0,80	76	2750
CAI 540 2M	OW 486 3	IP55	single-phase	1450	90	2	850	50	4,30	-	83	2750
CAI 540 2T	OW 487 1	IP55	three-phase	1450	90	2	800	50	2,73	1,57	83	2750